

410 Constitution Avenue, 11th Floor
Meridian, Mississippi 39301
601-482-9746
<https://lauderdalecounty.org>



ADDENDUM NO. 1
Total Pages: 4

Issued: April 25, 2023

BID NO.: 3941

BID NAME: COURTROOM FURNITURE - LAUDERDALE COUNTY COURTHOUSE COMPLEX

The following revisions and additions are to become a part of the Bid Documents of the above referenced bid. Acknowledge receipt of this Addendum by signing **page 13** of the bid packet documents.

The Bidders are responsible for bringing this Addendum to the attention of their Subcontractors and/or Material Suppliers.

1. BID DATE – is amended to the following:

- a. The Bid Due Date has been extended by five (5) working days.
- b. The revised Bid Due Date is **Wednesday, May 10, 2023.**
- c. The Bid Due Time has been revised to **10:00 A.M.**

2. ADDITIONAL FURNITURE – has been added and is a part of this addendum to include the following:

- a. Item Description: Wooden Chairs
- b. Item Quantity: 44 (forty-four)
- c. Addendum No. 1 Bid Form
- d. Wooden Chair Specs

ADDENDUM NO. 1 BID FORM - WOODEN CHAIRS

BID NO. 3941: COURTROOM FURNITURE - LAUDERDALE COUNTY COURTHOUSE COMPLEX

Proposal of _____, an
(individual) (partnership) (corporation) organized under the laws of the
State of _____.

For the additional furniture to be included as an addendum to the above-mentioned bid, we, the undersigned,
hereby offer to enter into a Contract to provide forty-four (44) wooden chairs for a Sum of:

ADDENDUM TOTAL AMOUNT: _____

_____ **dollars**
(Amount Written in Words)

\$ _____
(Dollar Value)

Bidders should follow the format above for submitting pricing. Price should be inclusive of the contractor's cost for any additional labor and delivery associated with this addendum.

Please provide the following information:

Estimated Build Time: _____

Estimated Delivery Date: _____

SIGNATURE: _____

NAME & TITLE: _____

TELEPHONE: _____

ADDRESS: _____

EMAIL: _____

THIS FORM MUST BE COMPLETED AND RETURNED WITH YOUR BID

ADDENDUM NO. 1 BID SPECS

SPECIFICATIONS - WOODEN CHAIRS

1.0 GENERAL

1.1 DESCRIPTION

- A. Wooden chairs are to be coordinated with Attorney Tables, Pew Benches and Jury Seating. Wooden Chairs, Pew Benches, Attorney Tables and Jury Seating must be provided by a single manufacturer, coordinating consistent wood, fabric, and finish from the same production run.

1.2 QUALITY ASSURANCE

- A. Manufacturer Qualification: Manufacturer shall have been regularly engaged in the manufacture of similar items for a minimum of twenty (20) years and shall have a history of successful production acceptable to the architect.

1.3 SUBMITTALS

- A. The manufacturer or manufacturer's rep shall submit product data, shop drawings, fabric samples, and stain/finish samples upon request, prior to fabrication of chairs.
- B. Product manufacturer must provide current Contractor License with the State of Mississippi.
- C. The manufacturer or manufacturer's rep shall field measure project and generate as-built, computer-generated floor plan layouts for final approval prior to fabrication.

1.4 DELIVERY, STORAGE, AND HANDLING

- A. The manufacturer shall be responsible for coordinating timely delivery with owner/contractor to prevent any storage or handling of product by owner/contractor prior to assembly and installation.

2.0 PRODUCTS

2.1 MATERIALS & CONSTRUCTION

- A. Chair Back: 5-ply construction, with a core of ½" plywood, two plys crossband of 1/8" hardboard (64.2 lb density), with one ply Solid Maple on the front and rear side of the chair. The back cap shall be 5/4 premium Solid Maple. The cap shall be attached using a hydraulic press using assembly glue and a press fit joint and shall have an under-cap support molding for added strength. Seat back shall be 20" wide.
- B. Chair Seat: Solid Maple construction, ergonomically contoured to match the contour of the pew benches. Seat width shall be 20" wide, non-stacking.
- C. Chair Frame and Chair Arms: Chair frame and arms shall be constructed using only Solid Maple components. Leg to frame supports shall use mortise/tenon joint construction. Leg to seat supports shall use dovetail joint connections.
- D. Finish: Finish must be a 2K polyurethane finish, resistant to hand sanitizers. Stain, sealer, and topcoat to be a formaldehyde free formulation. Stain color shall be matched to owner's sample. Stain shall be applied using a manually operated spray system, then brushed or hand wiped to ensure thorough penetration, and allowed to fully air dry. A two-component polyurethane sealer shall then be applied using a manually operated spray system and oven cured. The final topcoat shall be a two-component, polyurethane applied using a manually operated spray system, and oven cured. The topcoat shall be UV stable to prevent yellowing and shall be specially formulated to provide excellent scratch resistance and protection from household chemicals.

3.0 EXECUTION

3.1 INSTALLATION

- A. The manufacturer shall be responsible for all delivery, unloading, assembly, and complete installation of chairs, using factory trained regional installation crews. Moldings shall be attached with concealed pins to cover exposed screw heads.

3.2 WARRANTY

- A. The manufacturer shall provide a written twenty-five (25) year warranty (15 years on upholstery) against defects in materials and workmanship.

Chair Measurements/Dimensions:

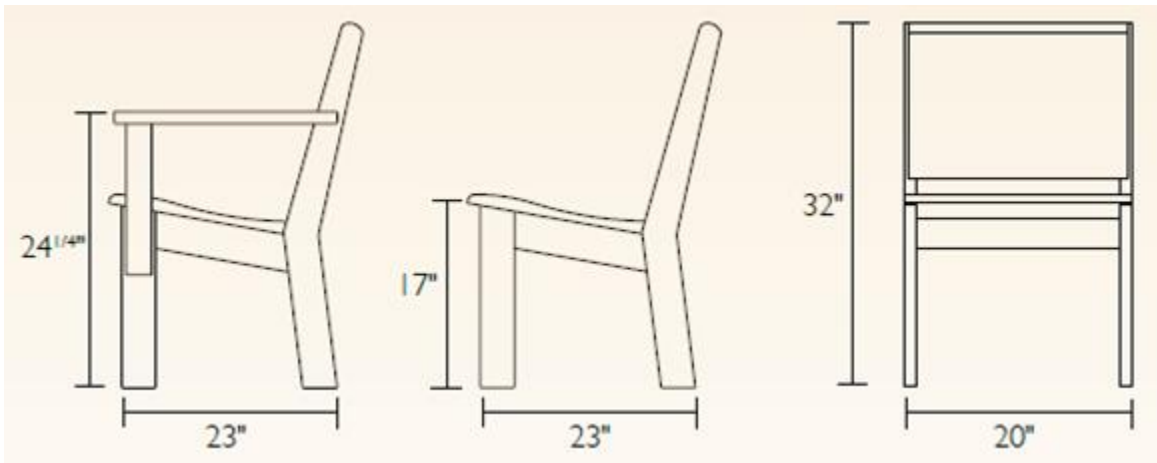

END OF SECTION

**END OF ADDENDUM
NO. 1**